

SPECIFICATION SHEET

2-Door Microwave/Open Shelf Wall Cabinet with Finger Pull

Code: MK158



Features

- Microwave/Open Shelf Cabinet
- 2 Overhead Doors with Finger Pull
- Laminate Woodgrain & Solid Colours on MR Board
- **Default Dimensions (as pictured):**
W600 x H750 x D450

Variable Dimensions:

Width: 600-900mm
Height: 700-1000mm
Depth: 250-450mm

Note: For measurements outside the variable dimensions, please contact us.

Technical Details

Note: All measurements shown are in millimetres. Sizes are nominal.

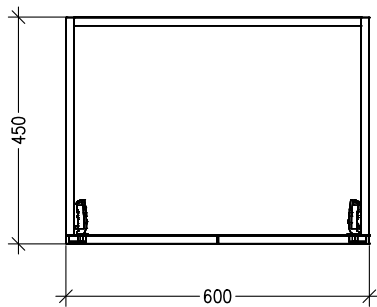

TOP VIEW

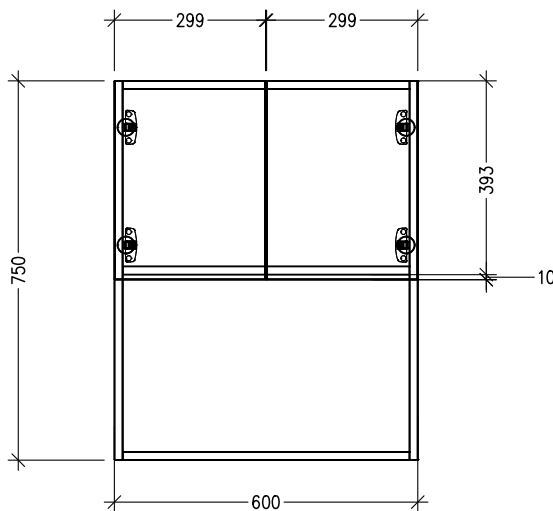
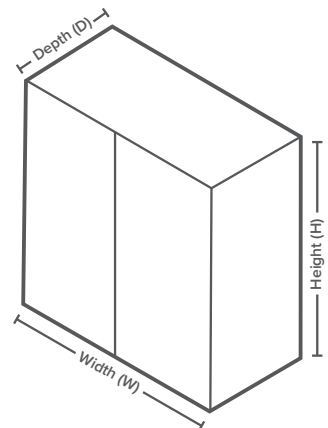

FRONT VIEW

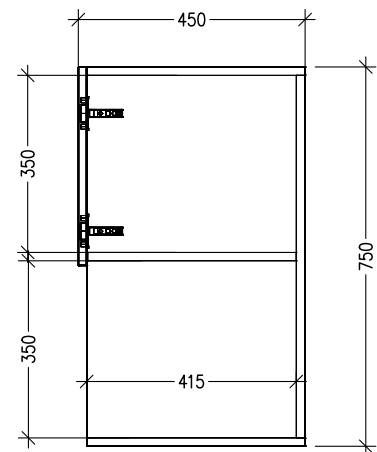

SIDE VIEW



Head Office: 30 Mill Road, Whanganui
0800 122 522 | sales@smartcab.co.nz
www.smartcab.co.nz