

SPECIFICATION SHEET

2 Drawer Base Cabinet with Inlay Rails

Code: MK108-CIR



Features

- 2 Drawer Base Cabinet
- Cabinet with Inlay Rails
- Laminate Woodgrain & Solid Colours on MR Board
- **Default Dimensions** (as pictured):
W600 x H880 x D590

Variable Dimensions:

Width: 400-599mm
Depth: 520-650mm

Note: For measurements outside the variable dimensions, please contact us.

Technical Details

Note: All measurements shown are in millimetres. Sizes are nominal.

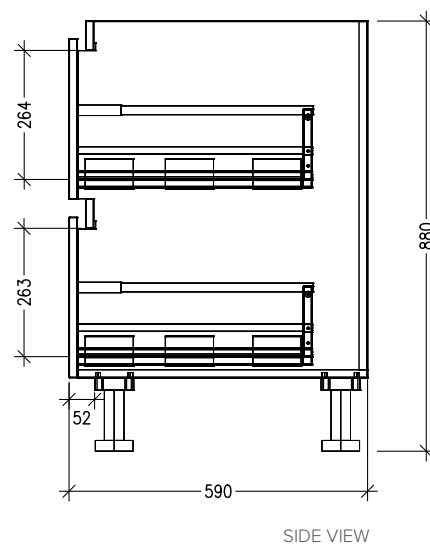
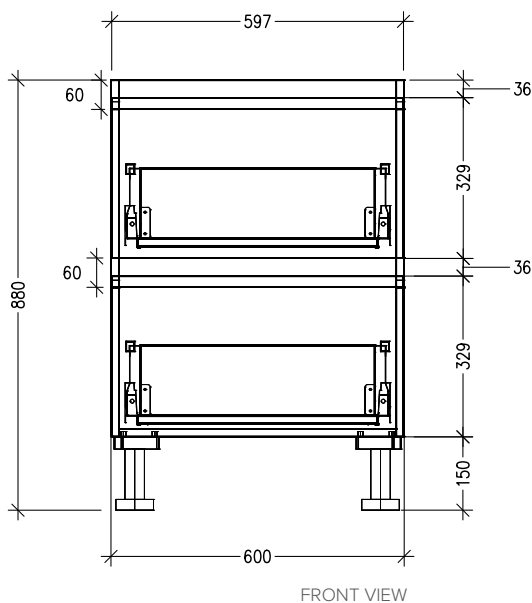
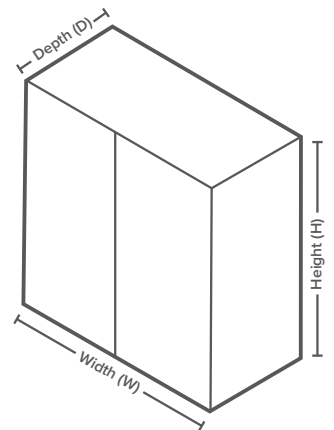
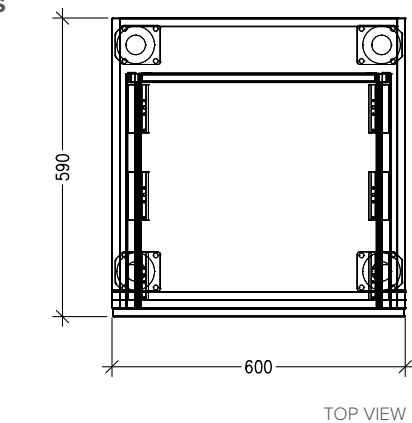

Head Office: 30 Mill Road, Whanganui
0800 122 522 | sales@smartcab.co.nz
www.smartcab.co.nz