

SPECIFICATION SHEET

4 Drawer Base Cabinet

Code: MK230-CHN



Features

- 4 Drawer Base Cabinet
- Cabinet Designed for Handles
- Laminate Woodgrain & Solid Colours on MR Board
- **Default Dimensions** (as pictured):
W600 x H880 x D590

Variable Dimensions:

Width: 600-900mm
Depth: 520-650mm

Note: For measurements outside the variable dimensions, please contact us.

Technical Details

Note: All measurements shown are in millimetres. Sizes are nominal.

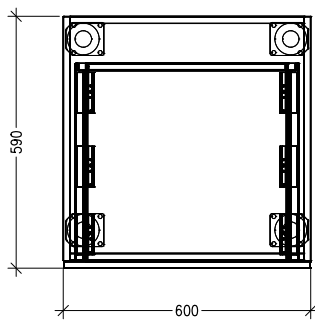

TOP VIEW

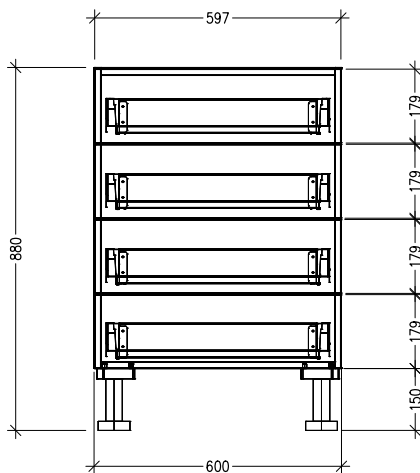
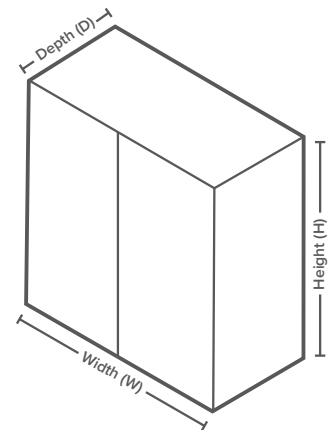

FRONT VIEW

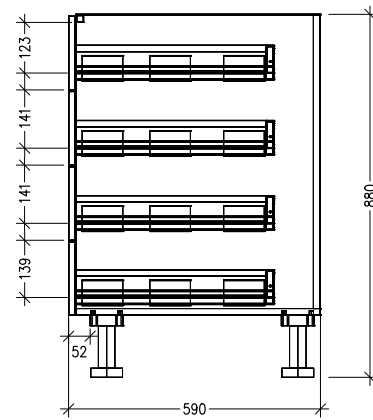

SIDE VIEW



Head Office: 30 Mill Road, Whanganui
0800 122 522 | sales@smartcab.co.nz
www.smartcab.co.nz